



## COMMISSION INTERNATIONALE DE KARTING - FIA



### MOTEUR / ENGINE OK

Constructeur	<i>Manufacturer</i>	OTK KART GROUP S.R.L. (ITALY)
Marque	<i>Make</i>	<b>VORTEX</b>
Modèle	<i>Model</i>	<b>DDS</b>
Type d'admission	<i>Inlet type</i>	<b>REED VALVE</b>
Durée de l'homologation	<i>Validity of the homologation</i>	9 ans / 9 years
Nombre de pages	<i>Number of pages</i>	18

La présente Fiche d'Homologation reproduit descriptions, illustrations et dimensions du moteur au moment de l'homologation par la CIK-FIA. La hauteur du moteur complet sur les photos doit être de 7 cm minimum.

*This Homologation Form reproduces descriptions, illustrations and dimensions of the engine at the time the CIK-FIA conducted the homologation. The height of the complete engine on all photographs must be as a minimum 7 cm.*



PHOTO DU MOTEUR CÔTÉ PIGNON  
PHOTO OF DRIVE SIDE OF ENGINE

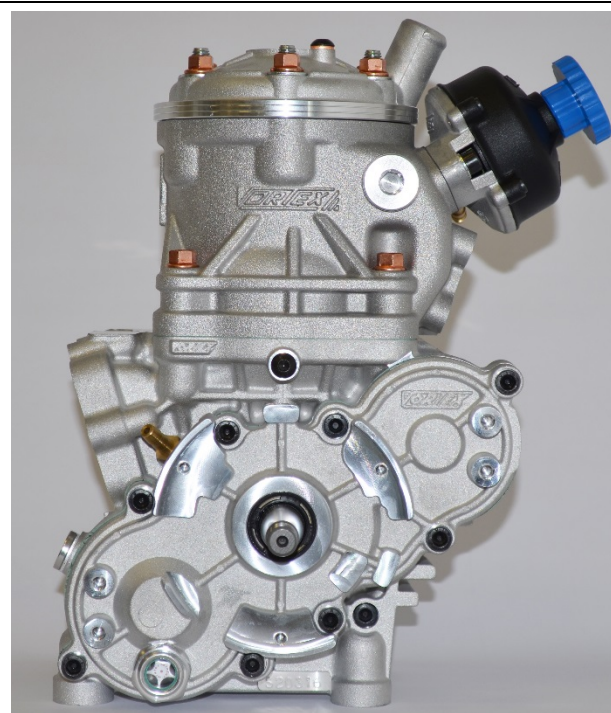

PHOTO DU MOTEUR CÔTÉ OPPOSÉ  
PHOTO OF OPPOSITE SIDE OF ENGINE

Signature et tampon de l'ASN  
*Signature and stamp of the ASN*



Signature et tampon de la CIK-FIA  
*Signature and stamp of the CIK-FIA*



**PHOTO DU MOTEUR COMPLET COTÉ  
PIGNON**

**PHOTO OF DRIVE SIDE OF THE COMPLETE  
ENGINE**



**PHOTO DU MOTEUR COMPLET COTÉ  
OPPOSÉ AU PIGNON**

**PHOTO OF OPPOSITE DRIVE SIDE OF THE  
COMPLETE ENGINE**



**PHOTO DE L'ARRIÈRE DU MOTEUR  
COMPLET**

**PHOTO OF THE REAR OF THE COMPLETE  
ENGINE**



**PHOTO DE L'AVANT DU MOTEUR COMPLET**

**PHOTO OF THE FRONT OF THE COMPLETE ENGINE**

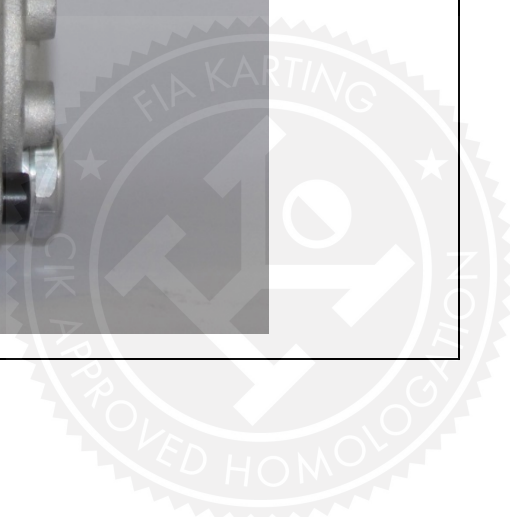

**PHOTO DU MOTEUR COMPLET VU DU HAUT**

**PHOTO OF THE COMPLETE ENGINE TAKEN FROM ABOVE**



**PHOTO DU MOTEUR COMPLET VU DU  
DESSOUS**

**PHOTO OF THE COMPLETE ENGINE TAKEN  
FROM BELOW**

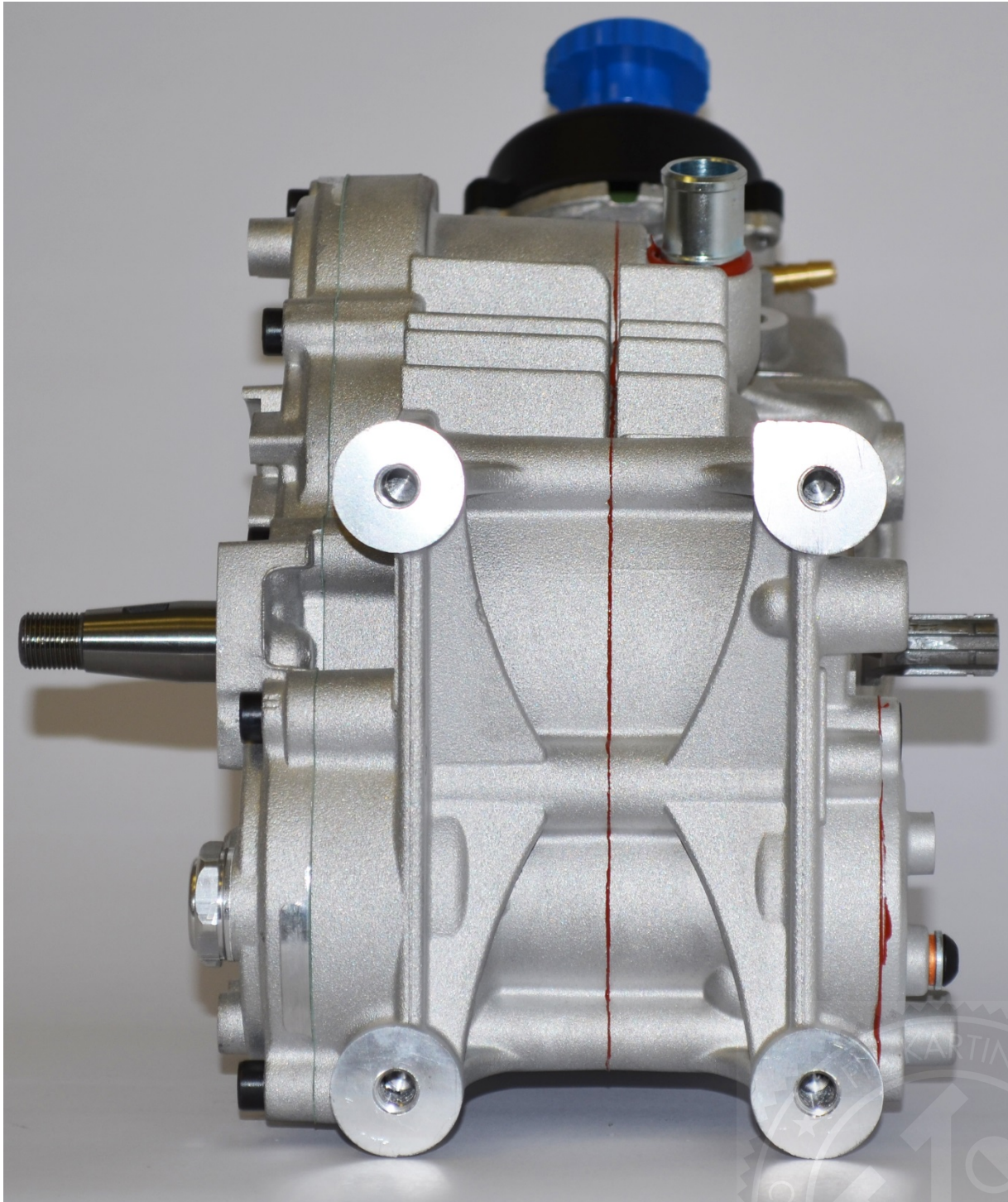

INFORMATIONS TECHNIQUES	TECHNICAL INFORMATION
-------------------------	-----------------------

A	CARACTÉRISTIQUES	A	CHARACTERISTICS
	Le nombre de décimales doit être de 2 ou en accord avec la tolérance appliquée.		<i>The number of decimal places must be 2 or comply with the relevant tolerance.</i>
			Tolérances / remarques <i>Tolerances &amp; remarks</i>
	<b>Cylindre</b>		<b>Cylinder</b>
	Volume du cylindre		<i>Volume of cylinder</i> <b>124.96 cm<sup>3</sup></b> <u><math>\leq 125\text{cm}^3</math></u>
	Alésage d'origine		<i>Original bore</i> <b>54.05 mm</b> --
	Alésage théorique maximum		<i>Theoretical maximum bore</i> <b>54.289 mm</b> --
	Course		<i>Stroke</i> <b>54 mm</b> --
	Nombre de canaux de transfert, cylindre/carter		<i>Number of transfer ducts, cylinder/sump</i> <b>5 / 5</b> --
	Nombre de lumières / canaux d'échappement		<i>Number of exhaust ports / ducts</i> <b>3</b> --
	Forme de la chambre de combustion		<i>Shape of the combustion chamber</i> <b>SPHERICAL WITH VARIABLE RADIUS+ SQUISH</b>
	<b>Vilebrequin</b>		<b>Crankshaft</b>
	Nombre de paliers		<i>Number of bearings</i> <b>2</b> --
	Diamètre des paliers		<i>Diameter of bearings</i> <b>25</b> ±0.1mm
	Poids minimum du vilebrequin		<i>Minimum weight of crankshaft</i> <b>1763 g</b> minimum
	<b>Arbre d'équilibrage</b>		<b>Balance shaft</b>
	Poids minimum de l'arbre d'équilibrage		<i>Minimum weight of balance shaft</i> <b>196g</b> minimum
	Pourcentage d'Equilibrage		<i>Percentage of balancing</i> <b>25%</b> minimum
	<b>Bielle</b>		<b>Connecting rod</b>
	Longueur (entre-axe) de la bielle		<i>Connecting rod centreline</i> <b>104mm</b> ±0.2mm
	Diamètre de la tête de bielle		<i>Diameter of big end</i> <b>26mm - 28mm</b> ±0.05mm
	Diamètre du pied de bielle		<i>Diameter of small end</i> <b>19mm</b> ±0.05mm
	Poids minimum de la bielle		<i>Min. weight of the connecting rod</i> <b>105g</b> minimum





<b>Piston</b>	<b>Piston</b>		
Nombre de ségments du piston	<i>Number of piston rings</i>	<b>1</b>	
Poids minimum du piston avec segment	<i>Minimum weight of the bare piston including piston rings</i>	<b>OPTION 1</b> <b>OPTION 2</b>	<b>109g</b> minimum
Poids minimum du piston avec segment	<i>Minimum weight of the bare piston including piston rings</i>	<b>OPTION 3</b> <b>OPTION 4</b>	<b>105g</b> minimum
<b>Axe du piston</b>	<b>Gudgeon pin</b>		
Poids minimum	<i>Minimum weight</i>	<b>27.9 g</b>	Minimum

<b>B</b>	<b>ANGLES D'OUVERTURE</b>	<b>B</b>	<b>OPENING ANGLES</b>
De l'échappement	<i>Of the exhaust</i>		<i>According to the regulations</i>

<b>C</b>	<b>MATÉRIAU</b>	<b>C</b>	<b>MATERIAL</b>
Culasse	<i>Cylinder head</i>		<b>AL – SI – ALLOY</b>
Cylindre	<i>Cylinder</i>		<b>AL – SI – ALLOY - IRON CAST</b>
Carter	<i>Sump</i>		<b>AL – SI – ALLOY</b>
Vilebrequin	<i>Crankshaft</i>		<b>NI – CR – MO – STEEL</b>
Bielle	<i>Connecting rod</i>		<b>NI – CR – MO – STEEL</b>
Piston	<i>Piston</i>		<b>AL – SI – ALLOY</b>



D	PHOTOS, DESSINS & GRAPHIQUES	D	PHOTOS, DRAWINGS & GRAPHS
---	------------------------------	---	---------------------------

**D.1 CYLINDRE / CYLINDER UNIT**

DESSIN DU DÉVELOPPEMENT DU CYLINDRE  
sans dimensions

*DRAWING OF THE CYLINDER DEVELOPMENT  
without dimensions*

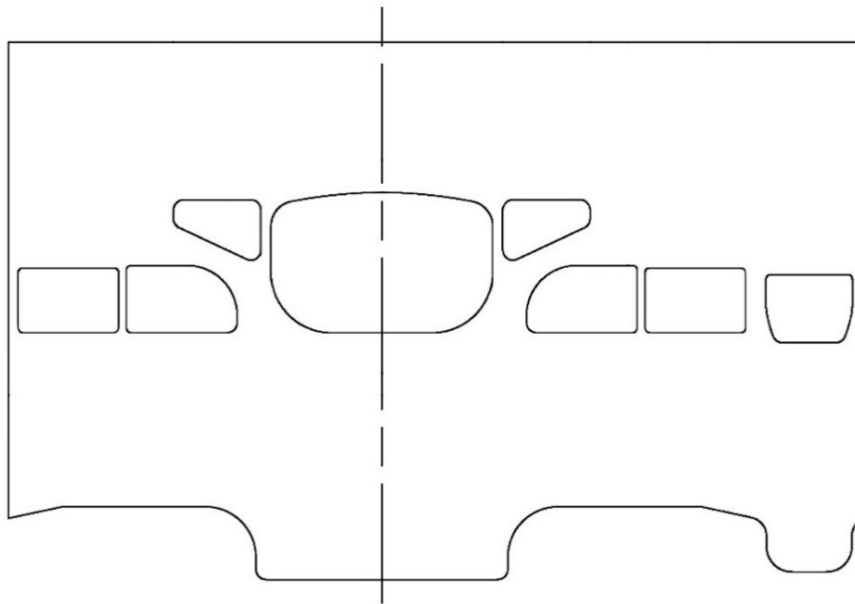

DESSIN DU PIED DU  
CYLINDRE sans  
dimensions

*DRAWING OF THE  
CYLINDER BASE  
without dimensions*

PHOTO DU PIED DU  
CYLINDRE

*PHOTO OF THE  
CYLINDER BASE*

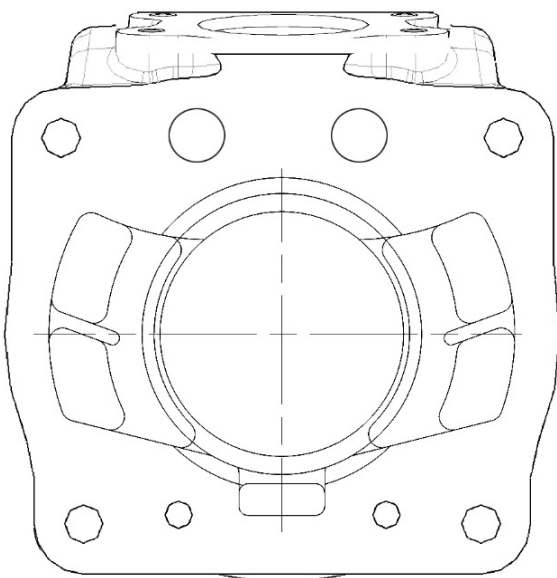

## ... Section D.1

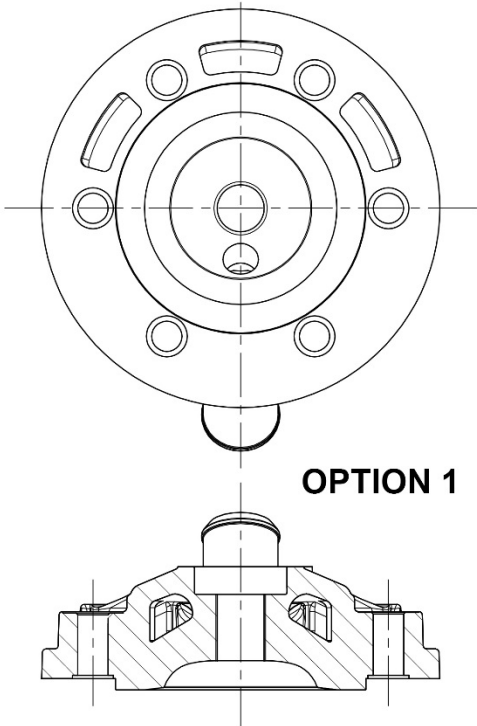
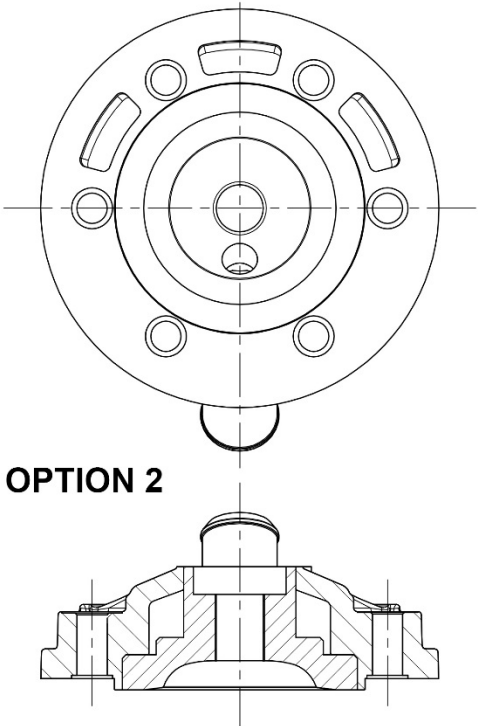
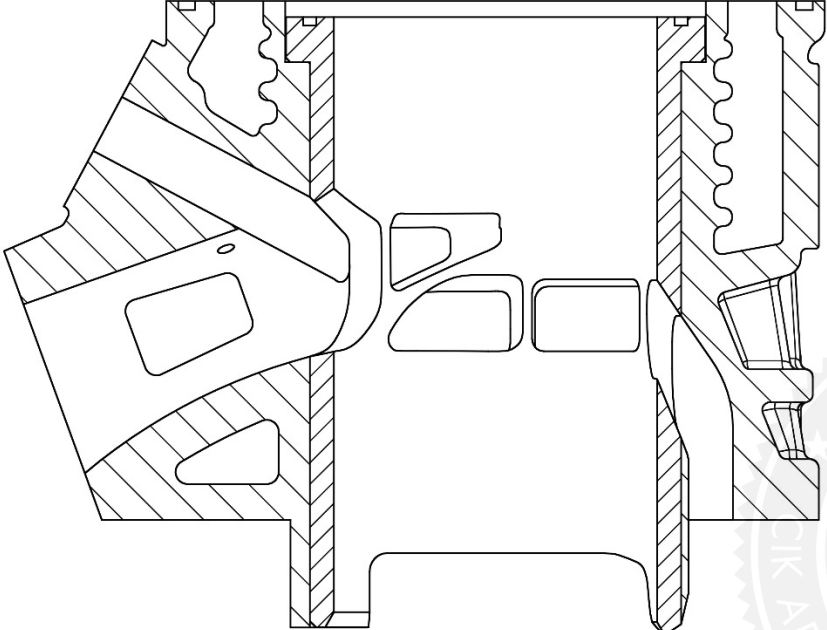
<p>DESSIN DE LA CULASSE ET DE LA CHAMBRE DE COMBUSTION sans dimensions</p>	<p>DRAWING OF THE CYLINDER HEAD AND OF THE COMBUSTION CHAMBER without dimensions</p>
 <p><b>OPTION 1</b></p>	 <p><b>OPTION 2</b></p>
<p>VUE EN COUPE VERTICALE DU CYLINDRE AVEC LA CHEMISE, sans dimensions</p>	<p>VERTICAL CROSS SECTION VIEW OF CYLINDER WITH LINER, without dimensions</p>
	

**D.2 BIELLE, CARTERS, VILEBREQUIN & PISTON / CONROD, CRANKCASE, CRANKSHAFT & PISTON**

PHOTO DE L'EMBIELLAGE  
PHOTO OF THE CRANKSHAFT & CONROD

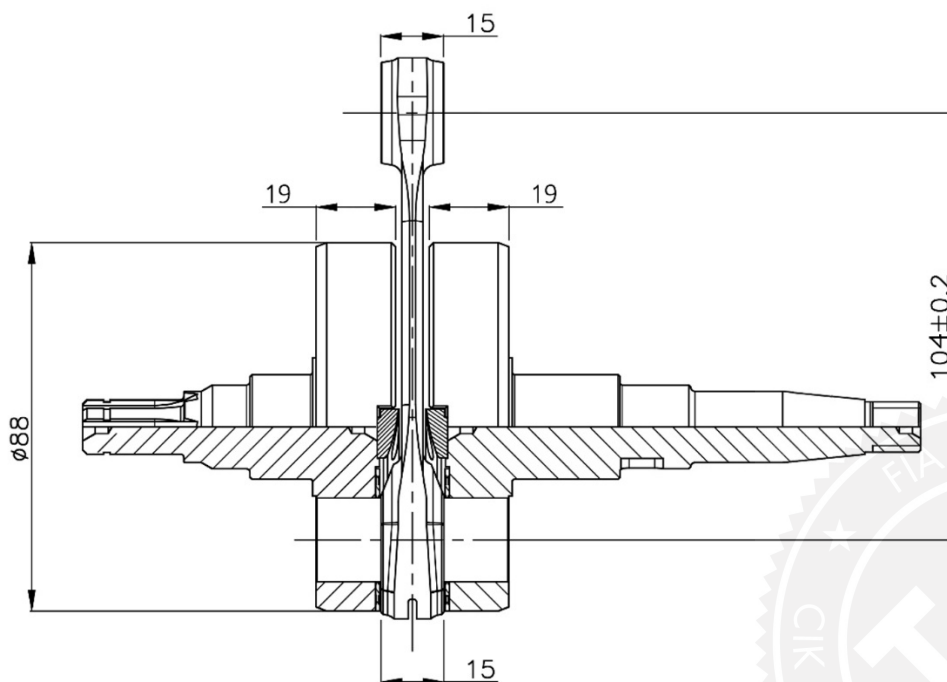

PHOTO DE LA BIELLE  
PHOTO OF THE CONROD



DESSIN DE L'ENSEMBLE VILEBREQUIN -  
BIELLE (DIMENSIONS avec tolérances, largeurs  
ped & tête de bielle, largeur & diamètre des  
contrepoids)

DRAWING OF THE CRANKSHAFT - CON ROD  
UNIT (DIMENSIONS incl. tolerances, big & small  
ends thickness, crank mass thickness &  
diameter )



DESSIN DU PISTON (DIMENSIONS PRINCIPALES avec tolérances)

DRAWING OF THE PISTON (MAIN DIMENSIONS incl. tolerances)

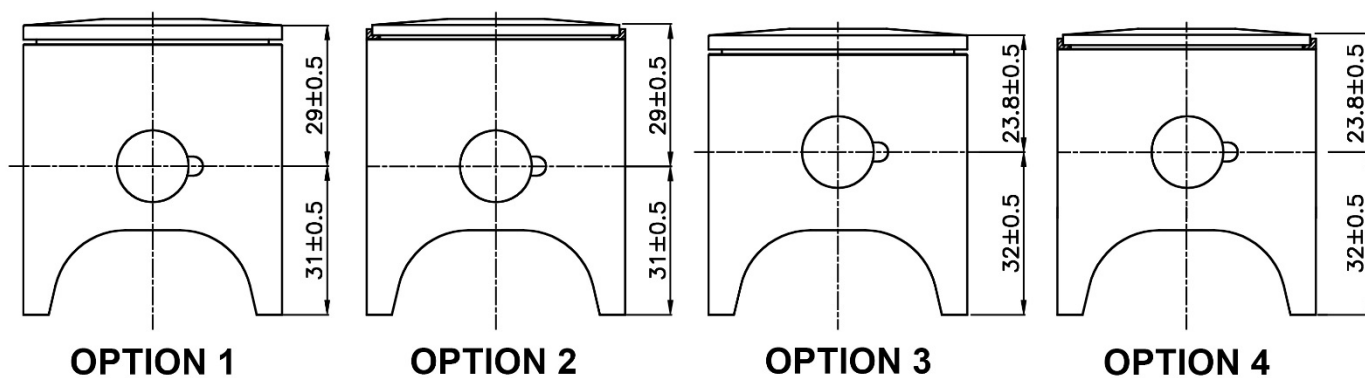

PHOTO INTÉRIEURE DU CARTER DROIT

PHOTO OF THE INSIDE OF THE RH CRANKCASE

PHOTO INTÉRIEURE DU CARTER GAUCHE

PHOTO OF THE INSIDE OF THE LH CRANKCASE



**D.3 ARBRE D'ÉQUILIBRAGE / BALANCE SHAFT**

PHOTO DE L'ARBRE D'ÉQUILIBRAGE

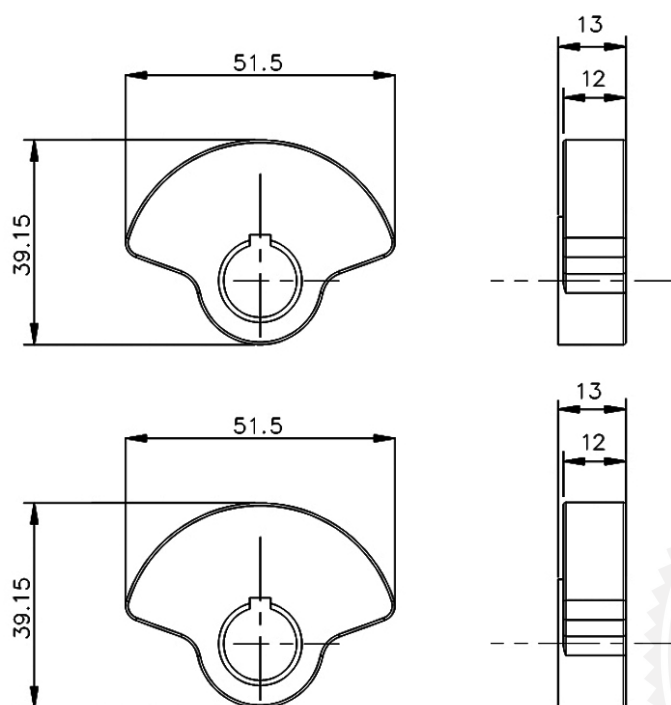
*PHOTO OF THE BALANCE SHAFT*DESSIN DE L'ARBRE D'ÉQUILIBRAGE  
(DIMENSIONS avec tolérances)*DRAWING OF THE BALANCE SHAFT  
(DIMENSIONS incl. tolerances)*

## D.4 CLAPETS &amp; POWER VALVE / REED VALVE &amp; POWER VALVE

DESSIN DE LA BOÎTE À CLAPETS  
(DIMENSIONS avec tolérances)

DRAWING OF THE REED VALVE  
(DIMENSIONS incl. tolerances)

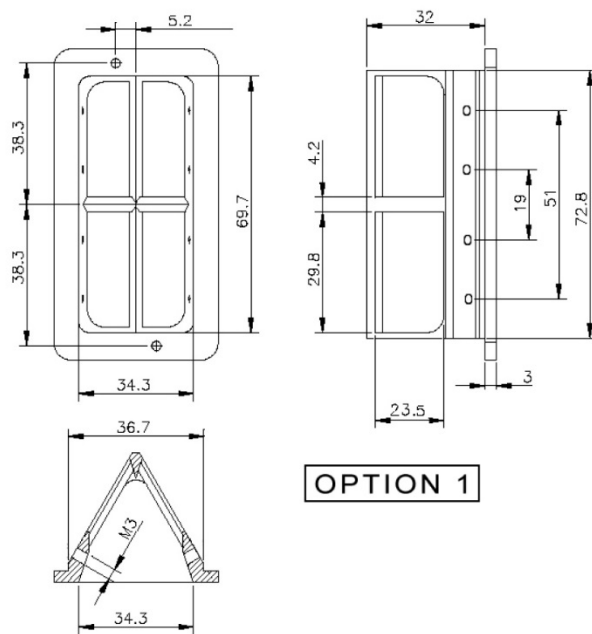

OPTION 1

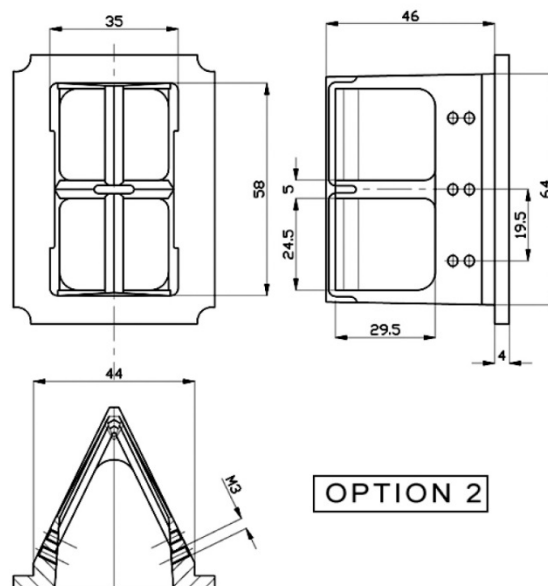

OPTION 2

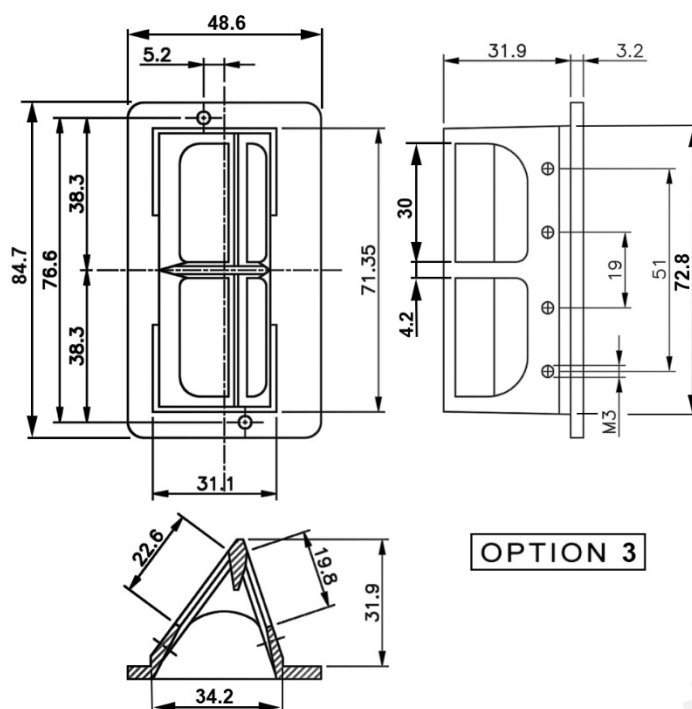

OPTION 3

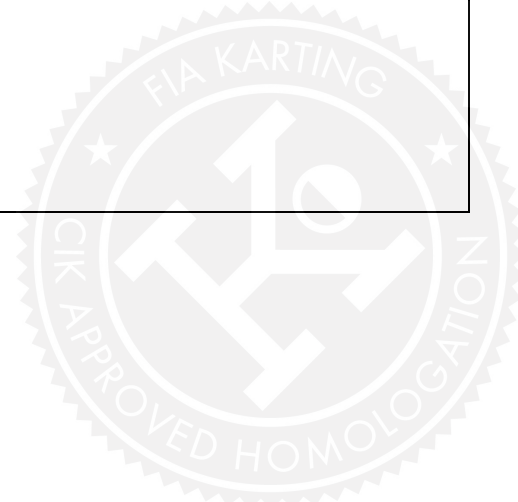

## ... Section D.4

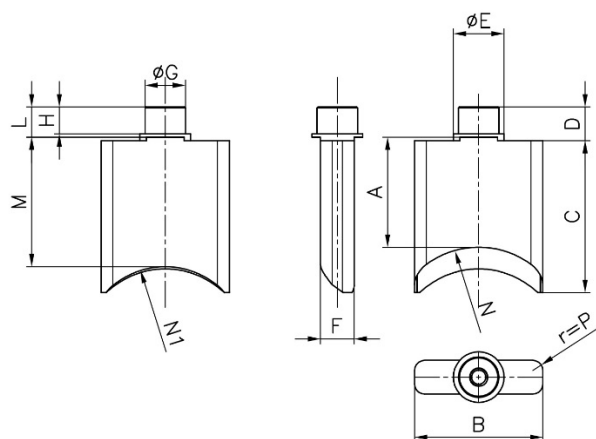
DESSIN EXPLOSE ET DENOMINATION DES  
ELEMENTS DE LA POWER VALVEEXPLODED DRAWING AND DESIGNATION OF  
THE POWER VALVE COMPONENTS

PARAMETER	DIMENSIONS		TOLERANCE	
	in mm (or ° if angle)		in mm (or ° if angle)	
A	33.2		± 0.5	
B	38		± 0.1	
C	45		± 0.5	
D	10		± 0.1	
E	15		± 0.1	
F	10		± 0.1	
G	12		± 0.1	
H	8		± 0.1	
L	9		± 0.1	
M	39.4		± 0.5	
N ( 3D surface n° 2 )	27.4		± 0.5	
N1 ( 3D surface n° 1 )	24.3		± 0.5	
P	3		± 0.1	
Q	16		± 0.1	
Ø	62		± 2	
B1	38.2		± 0.2	
F1	10.15		± 0.2	
P1	3.1		± 0.2	
Z	4		Maximum	

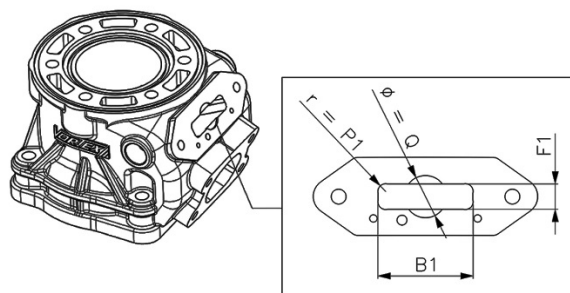

Le dessin explosé de la power valve devra comprendre le tableau indiquant toutes les dimensions indiquées sur le dessin technique n° 22, y compris celles marquées « free ».

The exploded view of the power valve shall include the table indicating all the measurements shown on the technical drawing No. 22, including those marked "free".









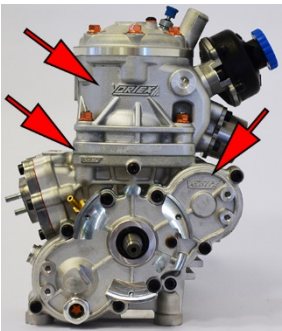

**D.5 MARQUAGE PIECES PRINCIPALES / MAIN PARTS MARKING**

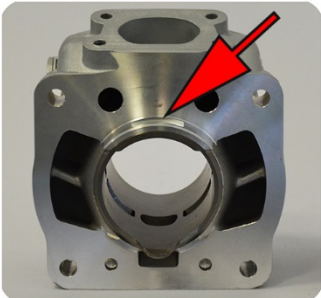
**Pour chaque pièce, photo globale avec le marquage et photo avec zoom sur le marquage**  
**For each part, global picture with marking and zoom picture on marking**

1. Fonderies de carter, couvercle d'engrenages, cylindre, culasse
2. Chemise en fonte
3. Demi-vilebrequins
4. Bielle
5. Arbre d'équilibrage
6. Engrenages
7. Couvercle (plastique) de la power valve
8. Guillotine de la power valve
9. Piston

1. Castings of crankcase, gears cover, cylinder, cylinder head
2. Cast iron liner
3. Half-crankshafts
4. Conrod
5. Balancer shaft
6. Gears
7. Power valve (plastic) cover
8. Power valve slide
9. Piston

Pièces N° / Parts no.	Photo globale / global picture	Zoom
1		
2		
3		
4		

5		
6		
7		
8		
9		

